

OPERATION, PARTS AND SAFETY MANUAL

MM SIGNODE®

PTC-16/19

STRAPPING TOOL

**IMPORTANT!
DO NOT DESTROY**

**It is the customer's responsibility to
have all operators and servicemen
read and understand this manual.**

Contact your local Signode representative
for additional copies of this manual.

⚠️ WARNING

READ THESE INSTRUCTIONS CAREFULLY.

FAILURE TO FOLLOW THESE INSTRUCTIONS CAN RESULT IN SEVERE PERSONAL INJURY.

GENERAL SAFETY CONSIDERATIONS

1. STRAP BREAKAGE HAZARD.

Improper operation of the tool or sharp corners on the load can result in strap breakage during tensioning, which could result in the following:

- A sudden loss of balance causing you to fall.
- Both tool and strap flying violently towards your face.

Failure to place the strap properly around the load or an unstable or shifted load could result in a sudden loss of strap tension during tensioning. This could result in a sudden loss of balance causing you to fall.

Read the tool's operating instructions. If the load corners are sharp use edge protectors. Place the strap correctly around a properly positioned load.

- Positioning yourself in-line with the strap, during tensioning and sealing, can result in severe personal injury from flying strap or tool. When tensioning or sealing, position yourself to one side of the strap and keep all bystanders away.
- Using strap not recommended for this tensioner can result in strap breakage during tensioning. Use the correct Signode products for your application.

2. TRAINING.

This tool must not be used by persons not properly trained in its use. Be certain that you receive proper training from your employer. If you have any questions contact your Signode Representative.

3. EYE INJURY HAZARD.

Failure to wear safety glasses with side shields can result in severe eye injury or blindness. Always wear safety glasses with side shields which conform to ANSI Standard Z87.1 or EN 166.



4. FALL HAZARD.

Maintaining improper footing and/or balance when operating the tool can cause you to fall. Do not use the tool when you are in an awkward position.

5. CUT HAZARD.

Handling strap or sharp parts could result in cut hands or fingers. Wear protective gloves.



WARNING

6. TOOL CARE.

Take good care of the tool. Inspect and clean it daily, lubricate it weekly and adjust when necessary. Replace any worn or broken parts.

7. WORK AREA.

Keep work areas uncluttered and well lighted.

Several types of strap can be used with this tool. Use the correct Signode products for your application. If you need help contact your Signode Representative.

CUTTING TENSIONED STRAP

Use only cutters designed for cutting strap; never use claw hammers, crowbars, chisels, axes or similar tools. Such tools will cause the strap to fly apart with hazardous force. Before using any Signode product, read its Operation and Safety Manual.

TABLE OF CONTENTS

	Page		Page
General Safety Instructions	2	Part Replacement & Adjustments	9
Specifications	5	Parts List & Exploded View	12
Major Components	5	Strap Size Conversion	15
Operating Instructions	6		

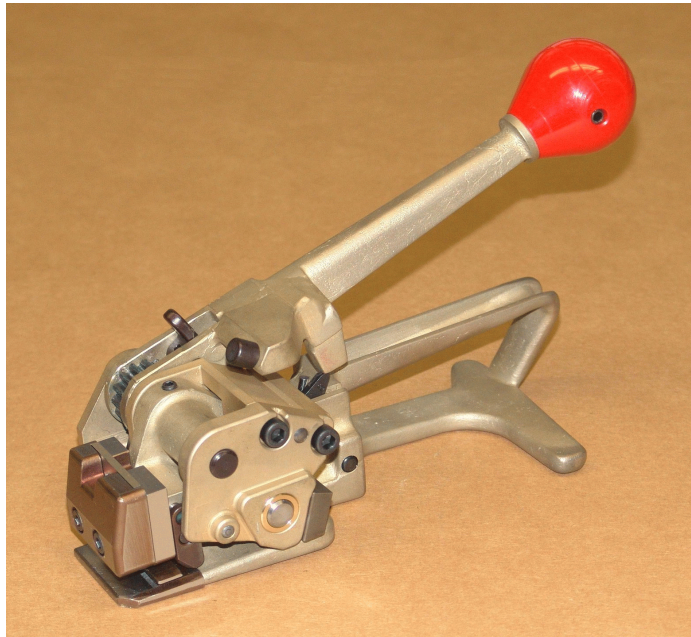

PTC-16 Tensioner, Part Number 426060
PTC-19 Tensioner, Part Number 426040

SPECIFICATIONS

MODEL	STRAP			RECOMMENDED SEALER (SEAL)
	TYPE	WIDTH	THICKNESS	
PTC-16	High Strength Tenax	16mm (.629")	0.030" to 0.044" (0.76-1.11mm)	D58 (58DY)
PTC-19	High Strength Tenax	19mm (.748")	0.045" to 0.055" (1.14-1.40mm)	D34 (34DY)

NOTE: PTC-16 tools are factory configured for use with 16mm Tenax Strapping.
 PTC-19 tools are factory configured for use with 19mm Tenax Strapping.

MAJOR COMPONENTS

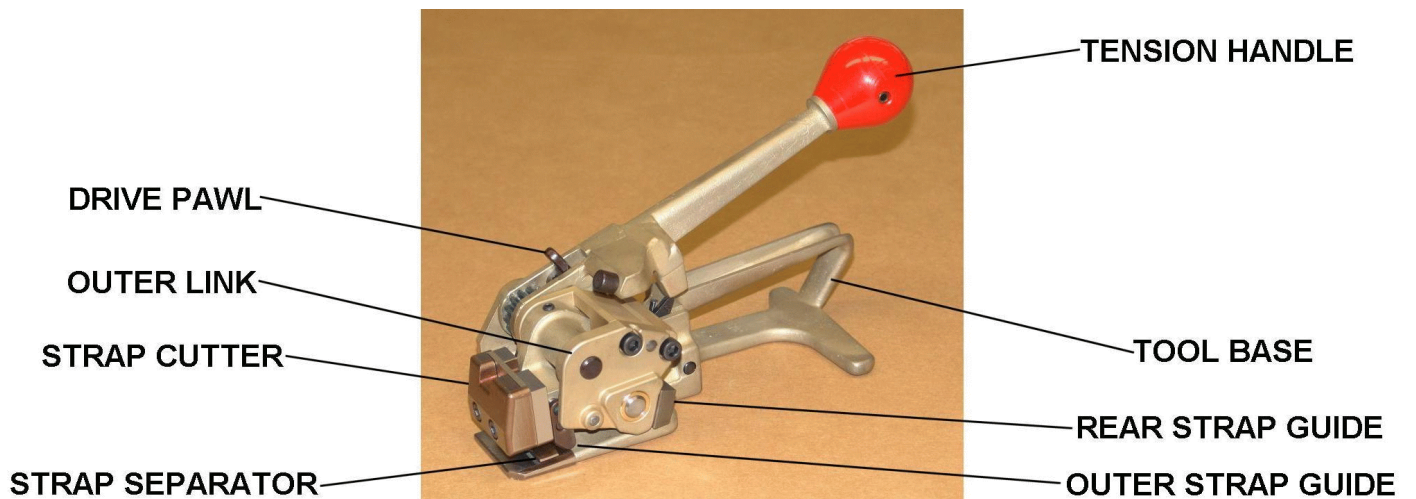

OPERATING INSTRUCTIONS

WARNING

Wear safety glasses. Stand to one side of the strap when tensioning.
Make sure all bystanders are clear before proceeding.

PLEASE NOTE: Do not operate tool without strap, as damage to the tool may occur.

1. With the dispenser placed behind you, bring the strap over the top and around the package, place the straps together and remove any excess slack. Hold the straps together with your left hand.



2. Using your right hand, squeeze the base and tension handle together to raise the feedwheel and open the strap path.

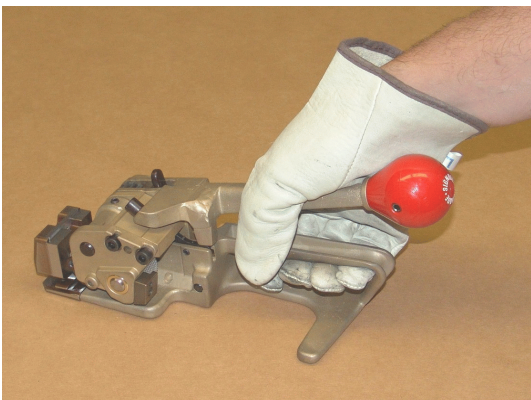

3. Using your left hand, insert the upper and lower straps into the tool at the same time.



As the strap is inserted make sure the top strap is above the blade of the of the cutter block and the lower strap is under the block as shown by the arrows. Leave a tail of 3 or 4 inches in front of the tool of the lower strap.

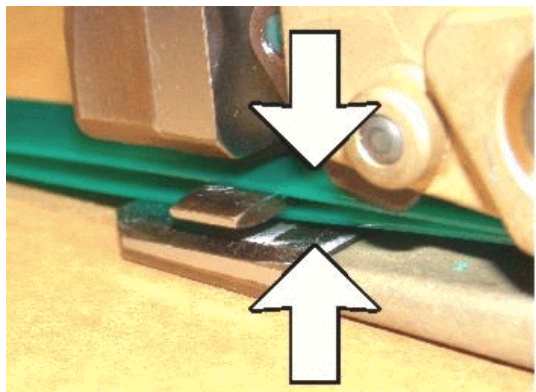

Release the tension handle and check to be sure the strap guides over lap the strapping.

4. Remove any excess strapping by holding the tool base with your right hand. With the left hand pull back the top strap straight through the tool,

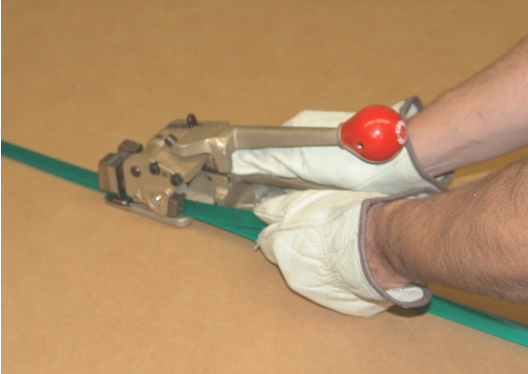

If the position of the tension handle needs to be adjusted or corrected, press the drive pawl to free the handle from the ratchet mechanism.

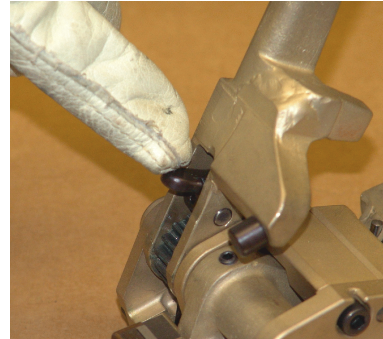

5. Place the proper seal on the strap making sure both top and bottom straps are contained by the seal and that the bottom strap extends under the seal.

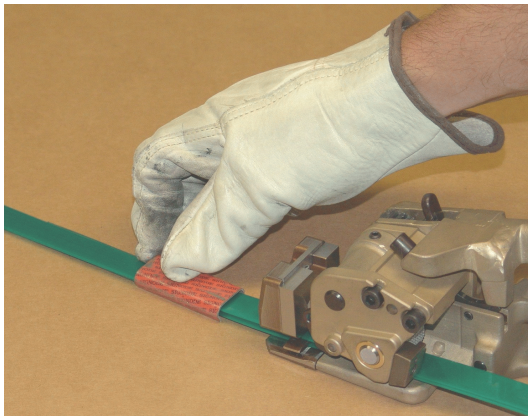

Note: After initial tension is applied it will be impossible to open the tool by squeezing the tension handle and the base together. Major force would be required and damage to the tool may occur. If necessary cut off the strapping and begin again.

7. Once the desired tension is reached, use the proper Signode sealer to crimp the seal. (Review the operation instructions of the sealer for proper operation and final joint appearance)

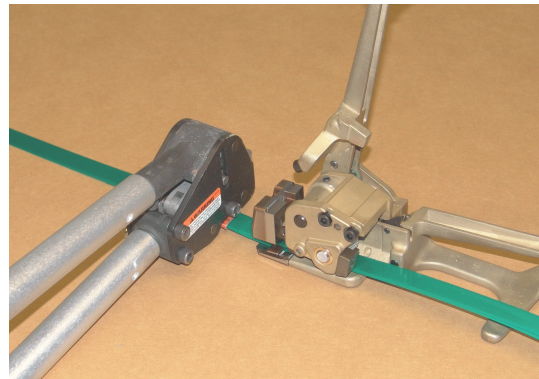

6. Operate the tension handle back and forth until the desired strap tension is reached.



... Continued

OPERATING INSTRUCTIONS, Continued

8. Cut the strap by pushing the tension handle forward as far as it will go. The operator should hear and feel a “snap” as the strap is being cut under tension.

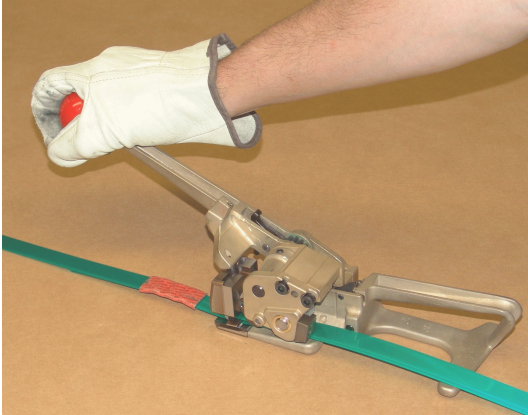

Bring the handle back to the rest position after cutting the strap.

9. Once again squeeze the tension handle and the base together to lift the feedwheel from the strap. Pivot the tool off the strap to complete the strapping cycle.



PART REPLACEMENT & ADJUSTMENTS

FEEDWHEEL REPLACEMENT

Over time and application conditions the feedwheel may become worn and may need to be replaced. Use the following instructions to replace the feedwheel.

1. Remove the two mounting screws which secure the outer link to the tool.
2. Remove the outer link.

NOTE: The outer guide link connects to a pin in the outer link. Make sure the link is placed over the pin when reassembling the tool.

3. Squeeze the tension handle and base together to lift the feedwheel away from the gripper plug. Slide the feedwheel off the shaft.

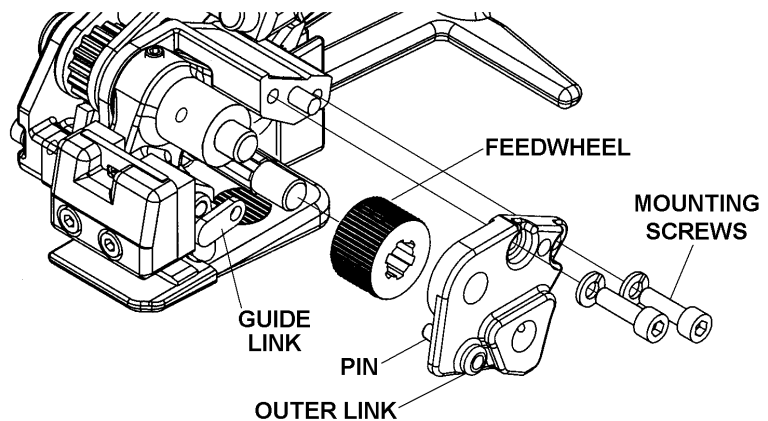

4. Replace feedwheel and reassemble tool. Check the feedwheel clearance if needed.

FEEDWHEEL CLEARANCE

The feedwheel to gripper plug clearance may require readjustment if the feedwheel or gripper plug has been replaced. The feedwheel clearance should also be inspected during routine tool maintenance procedures. Adjust the feedwheel clearance as follows:

1. Squeeze the tension handle and base together to open the feedwheel gap. Place 3 to 4 layers of .002", 1/2" wide (.05 x 12mm) shim stock between the feedwheel and the tension gripper. Make sure the shims are placed along the outer edge of the gripper.

NOTE: Using a single .008" (.20mm) shim is not recommended because a single thicker shim may not conform to the feedwheel shape, resulting in inaccurate clearance measurements.

2. Release the tensioner handle to pinch the shims between the feedwheel and the gripper. Holding the shims with one hand, pull gently on the shims towards the rear of the tool. If properly adjusted the tool should lightly tug at the shims. Clearance between the feedwheel and gripper plug at this point should fall between .008" to .016 (.20mm to .40mm).

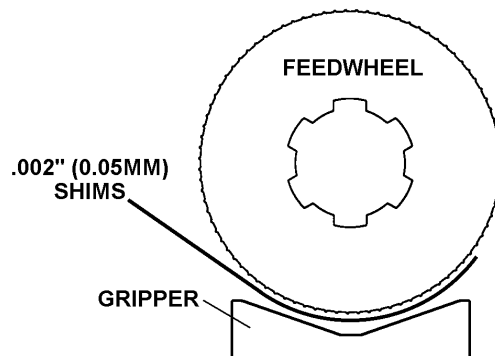

PART REPLACEMENT & ADJUSTMENTS, Continued

3. If the feedwheel needs to be adjusted, use a 2mm hex wrench to turn the adjustment screw which can be accessed through the bottom of the tool base.

Turn the adjustment screw clockwise for greater clearance and counter-clockwise for less clearance. Turn the adjustment screw only in small increments. After each adjustment, repeat the adjustment testing as described in step 2.

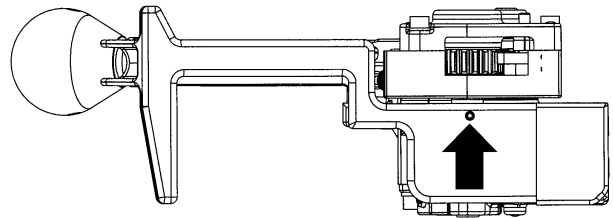

FEEDWHEEL ADJUSTMENT SCREW LOCATION

4. Once the proper clearance has been found the tool can be returned to service.

NOTE: Never turn out the adjustment screw more than 1/4 turn at a time without testing or completely remove the adjustment screw. These actions will severely damage both the feedwheel and tension gripper.

CUTTER BLADE REPLACEMENT

Over time and application conditions the cutter blade may become worn and may need to be replaced. Use the following instructions to replace the blade.

1. Remove the two mounting screws which secure the cover to the tool. Use caution as removing the cover will release the blade, spacers and compression spring.
2. Remove the cover and cutter blade.
3. Remove the compression spring from the old cutter blade and insert the spring in to the replacement blade.
4. Align the new cutter blade over the spacers and reinstall the cover.
5. Securely tighten the two mounting screws.

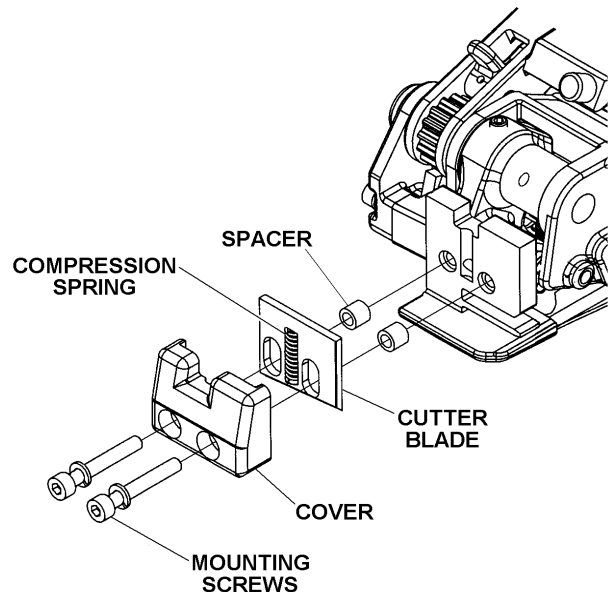

CHANGING STRAP SIZE

The following table illustrates the unique parts to a particular strap size for the PTC tool. If the strap size of the tool is to be changed, this table must be used to coordinate all the respective parts which must be reconfigured or replaced.

Follow all specified parts removal, replacement & adjustment procedures found in this manual when changing any of the strap conversion parts.

WARNING

Do not attempt to convert a tool's strap size without replacing/reconfiguring all of the specified parts for the conversion. Failure to replace/reconfigure all required parts may cause severe personal injury.

UNIQUE PARTS & CONFIGURATION TO SCM STRAP SIZES

KEY	QTY	DESCRIPTION	5/8" (16mm)	3/4" (19mm)
22	1	Outer Guide	Note-1	Note-2
23	1	Rear Guide	Note-3	Note-4
63	1	Nameplate	426343	426344

NOTES:

1. Outer Guide must be reinstalled behind link as shown (See Figure 1).
2. Outer Guide must be reinstalled in front of link as shown (See Figure 1).
3. Rear Guide must be removed and reinstalled with numerals "16" facing outwards (See Figure 2).
4. Rear Guide must be removed and reinstalled with numerals "19" facing outwards (See Figure 3).

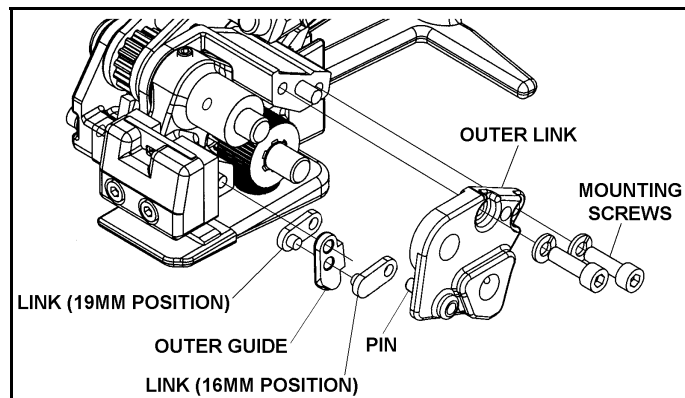

FIGURE 1

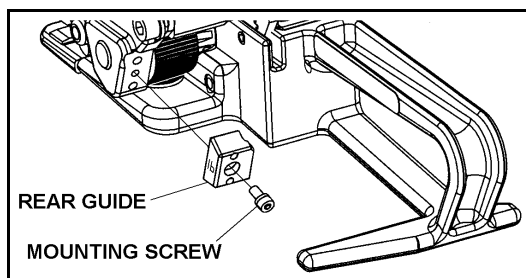

FIGURE 2
(16MM POSITION)

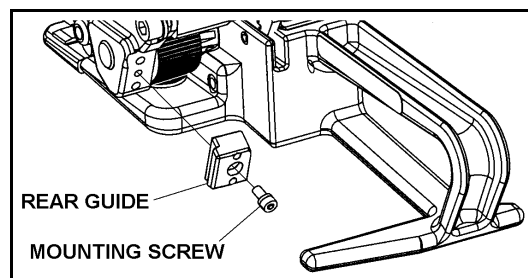

FIGURE 3
(19MM POSITION)

SIGNODE NEW TOOL WARRANTY

Signode Engineered Products Warrants that a new Signode strapping tool will operate per functional specifications for a period of sixty (60) days after the date of shipment to the owner's place of business. Normal wearing parts, as outlined in the Operation, Parts & Safety manual, are covered by a thirty (30) day warranty unless, in Signode's judgement, these parts have been subjected to abnormal or extreme usage. Signode's sole liability hereunder will be to repair or replace, without charge, F.O.B. Signode's Glenview, Illinois plant, any tool which proves to not operate per functional specifications within the stated period. Signode reserves the right to replace any tool which proves not to operate per functional specifications with a new or like-new tool of the same model if in Signode's judgement such replacement is appropriate. Any new replacement tool provided to an owner will carry a full sixty (60) day warranty. Any warranty repaired tool or like-new replacement tool will carry a warranty for the balance of the time remaining on the initial sixty (60) day warranty. This warranty will be extended to compensate for the time the tool is in Signode's possession for warranty repairs.

This warranty is void as to any tool which has been: (I) subjected to mis-use, misapplication, accident, damage, or repaired with other than genuine Signode replacement parts, (II) improperly maintained, or adjusted, or damaged in transit or handling; (III) used with improperly filtered, unlubricated air or improper strapping material, (IV) in Signode's opinion, altered or repaired in a way that affects or detracts from the performance of the tool.

SIGNODE MAKES NO WARRANTY, EXPRESSED OR IMPLIED, RELATING TO MERCHANTABILITY, FITNESS OR OTHERWISE EXCEPT AS STATED ABOVE AND SIGNODE'S LIABILITY AS ASSUMED ABOVE IS IN LIEU OF ALL OTHERS ARISING OUT OF OR IN CONNECTION WITH THE USE AND PERFORMANCE OF THE TOOL. IT IS EXPRESSLY UNDERSTOOD THAT SIGNODE SHALL IN NO EVENT BE LIABLE FOR ANY INDIRECT OR CONSEQUENTIAL DAMAGES INCLUDING, BUT NOT LIMITED TO, DAMAGES WHICH MAY ARISE FROM LOSS OF ANTICIPATED PROFITS OR PRODUCTION, SPOILAGE OF MATERIALS, INCREASED COSTS OF OPERATION OR OTHERWISE.

Considerable effort has been made to ensure that this product conforms to our high quality standards. However, should you experience any difficulties, please contact your Sales Representative providing samples and the manufacturing code specified on the tool.

PART #	DESCRIPTION	AREA OF USE
LUBRICANTS		
177029	GEAR HOUSING GREASE	CLUTCH DRIVES, INTERNAL GEARS, GEAR SETS
422792	WHITE LUBRIPLATE GR-132 GREASE	PNEUMATIC PARTS, AIR CYLINDERS, AIR VALVES, O-RINGS
422793	BLACK LUBRIPLATE 3000W GREASE	MOVING INTERNAL PARTS, JAWS, LINKS
432322	EP ACCROLUBE GREASE	HIGH FRICTION CONTACT PARTS
008556	LS-1236 AIR LINE OIL	AIR MOTORS, AIR VALVES
ADHESIVES		
422794	LOCTITE #222, PURPLE	LOW STRENGTH, SCREWS 1/4" (6MM) OR SMALLER SIZES
422795	LOCTITE #242, BLUE	MEDIUM STRENGTH, SCREWS 5/16" (8MM) OR LARGER SIZES
422796	LOCTITE #271, RED	HIGH STRENGTH, SEMI-PERMANENT SCREW APPLICATION
422797	LOCTITE #609, GREEN	PERMANENT, CURVED SURFACE PART CONTACT
274111	LOCTITE #380, BLACK MAX	PERMANENT, FLAT SURFACE PART CONTACT
CLEANING BRUSHES		
023963	SMALL BRUSH	FEEDWHEEL & GRIPPER TEETH
269589	LARGE BRUSH	FEEDWHEEL & GRIPPER TEETH